

Rotary Screw Compressors FSD Series

With the world-renowned SIGMA PROFILE 

Free air delivery 9.4 to 52.13 m³/min, Pressure 5.5 – 15 bar



FSD series

FSD – Setting the standard

KAESER KOMPRESSOREN pushes the boundaries of compressed air efficiency once again with its latest generation of FSD series rotary screw compressors. Not only do they deliver more compressed air for less power consumption, but they also combine ease of use and maintenance with exceptional versatility and environmentally responsible design.

FSD – The multi-saver

These high performance systems help save energy in various ways: 1) Flow-optimised SIGMA PROFILE rotors improve specific power. 2) The use of IE3 drive motors maximises energy efficiency (these motors will become mandatory in the EU from the 1st of January 2015). 3) Kaeser's 1:1 drive design eliminates the transmission losses associated with gear or V-belt driven systems, as the motor directly drives the airend. 4) The SIGMA CONTROL 2 compressor controller optimises performance by using specially developed control algorithms.

Ease of maintenance ensures savings

There's much more to KAESER's latest system design than initially meets the eye: The new internal component layout not only ensures even greater efficiency, but also allows direct access to all service and maintenance parts from the front of the unit. This saves both time and money when it comes to servicing.

Perfect partners

FSD series rotary screw compressors are the perfect partners for high efficiency industrial compressed air stations. The internal SIGMA CONTROL 2 compressor controller offers numerous communication channels, which allows seamless connection with advanced master controllers, such as KAESER's SIGMA AIR MANAGER, and in-house centralised control systems. This enables simple set-up and achieves unprecedented levels of efficiency.

Enhanced cooling

KAESER's innovative cooling concept features external coolers to provide significant user advantages: Because the ambient air that is drawn in is not pre-warmed, it provides significantly enhanced cooling performance. Moreover, cooler status can be checked at a glance and these compact units are easily cleaned from the outside.

Potential energy cost savings through heat recovery

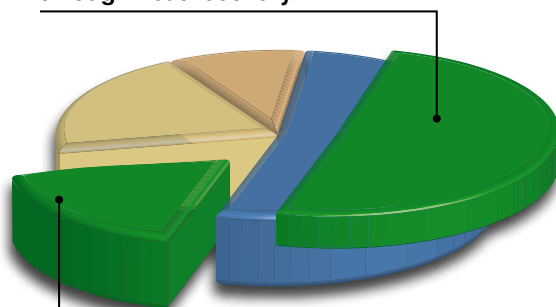

Energy cost savings through system optimisation



- Compressed air system investment
- Maintenance costs
- Energy costs
- Potential energy cost savings

Outstanding efficiency and service-friendliness



Image: FSD 571 SFC with variable speed control



FSD series

KAESER quality and efficiency for every need



SIGMA PROFILE

At the heart of every FSD system lies a premium quality airend featuring Kaeser's SIGMA PROFILE rotors. Flow-optimised for impressive performance, these advanced rotors help Kaeser systems set the standard for superior efficiency.



Maximum efficiency: IE3 motors

Long before the use of IE3 motors becomes mandatory in the EU on the 1st of January 2015, users can already enjoy the benefits that these premium efficiency motors have to offer by choosing Kaeser FSD series rotary screw compressors.



SIGMA CONTROL 2

The SIGMA CONTROL 2 ensures efficient control and system monitoring. The large display and RFID reader ensure easy communication and maximum security. Multiple interfaces offer exceptional flexibility, whilst the SD card slot makes updates quick and easy.



Radial fan

The quiet and powerful radial fan draws in cool ambient air through the cooler. Its high residual thrust means that the fan is not affected by contamination that is drawn in with the air and ensures sufficient power reserves to allow connection of long exhaust duct sections.

FSD SFC series

Variable speed control perfected



Image: FSD 571 SFC

Lubrication point for drive motor and fan motor

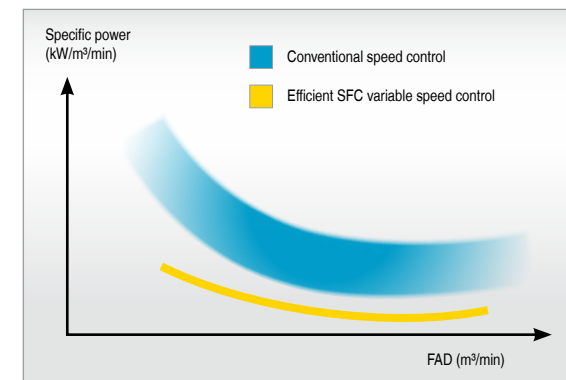

Optimised specific power

The variable speed compressor is the most heavily loaded piece of equipment in every compressor station. FSD-SFC models are therefore designed to provide maximum efficiency without running at extreme speeds. This saves energy, maximises service life and enhances reliability.

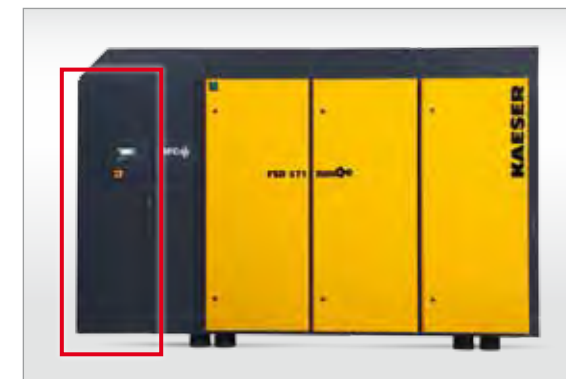

Separate SFC control cabinet

The SFC variable speed drive is housed in its own insulated control cabinet to shield it from heat from the compressor. A separate fan keeps operating temperatures in the optimum range to ensure maximum performance and service life.

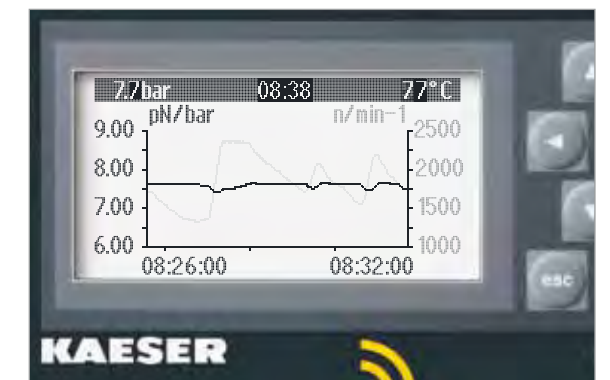

Precise pressure control

The volumetric flow rate can be adjusted within the control range according to pressure to suit actual compressed air demand. As a result, operating pressure is precisely maintained to within ± 0.1 bar. This allows maximum pressure to be reduced which saves both energy and money.



EMC-certified

It goes without saying that the SFC control cabinet and SIGMA CONTROL 2 are tested and certified both as individual components and as a system to EMC directive EN 55011 for Class A1 industrial power supplies.



FSD series

Innovative cooling concept with separated air flow



Low airoend discharge temperature

The large external compressed air aftercooler ensures low compressed air discharge temperatures even under unfavourable intake conditions. The low discharge temperature not only reduces the load on downstream treatment components, but also saves energy.



Low operating temperature

The oil cooler's generously sized cooling surfaces ensure low operating and airoend temperatures even under unfavourable intake conditions. This significantly enhances the reliability and availability of FSD packages.



Coolers cleaned from the outside

Unlike internally installed coolers, the exterior heat exchangers in FSD systems are easy to access and simple to clean. Because dirt build-up is easily spotted, operational reliability and availability are increased, which in turn also reduces service costs.



High residual thrust

The integrated radial fan guarantees maximum efficiency and provides high residual thrust. These characteristics enable excellent system cooling and generally allow reusable heat to be carried away via ducting without the need for a supplementary fan.

FSD series

Intelligent solutions



Your choice of heat exchanger

In water-cooled systems, integrated plate or tube-type heat exchangers are available, depending on the available water quality. Our compressed air specialists can advise you about which design is right for your particular application.



E-motors lubricated from the outside

Like all electrical motors, the compressor drive motor and fan motor in FSD systems require relubrication – yet this can be easily performed from the outside, even while the machine is running.

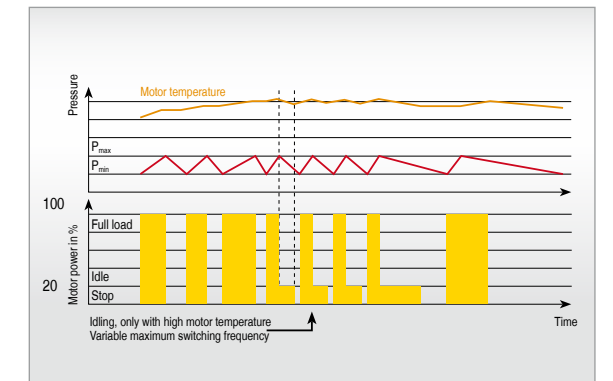

Efficient dynamic control

To calculate run-on periods, dynamic control monitors the motor winding temperature. This reduces both idling and energy consumption. The SIGMA CONTROL 2 offers additional control modes as required.



Service-friendly

Just as the air filter easy is to change from the front of the unit, all other maintenance components are also easy to access. This streamlines maintenance and service work, thereby reducing operating costs and increasing reliability.

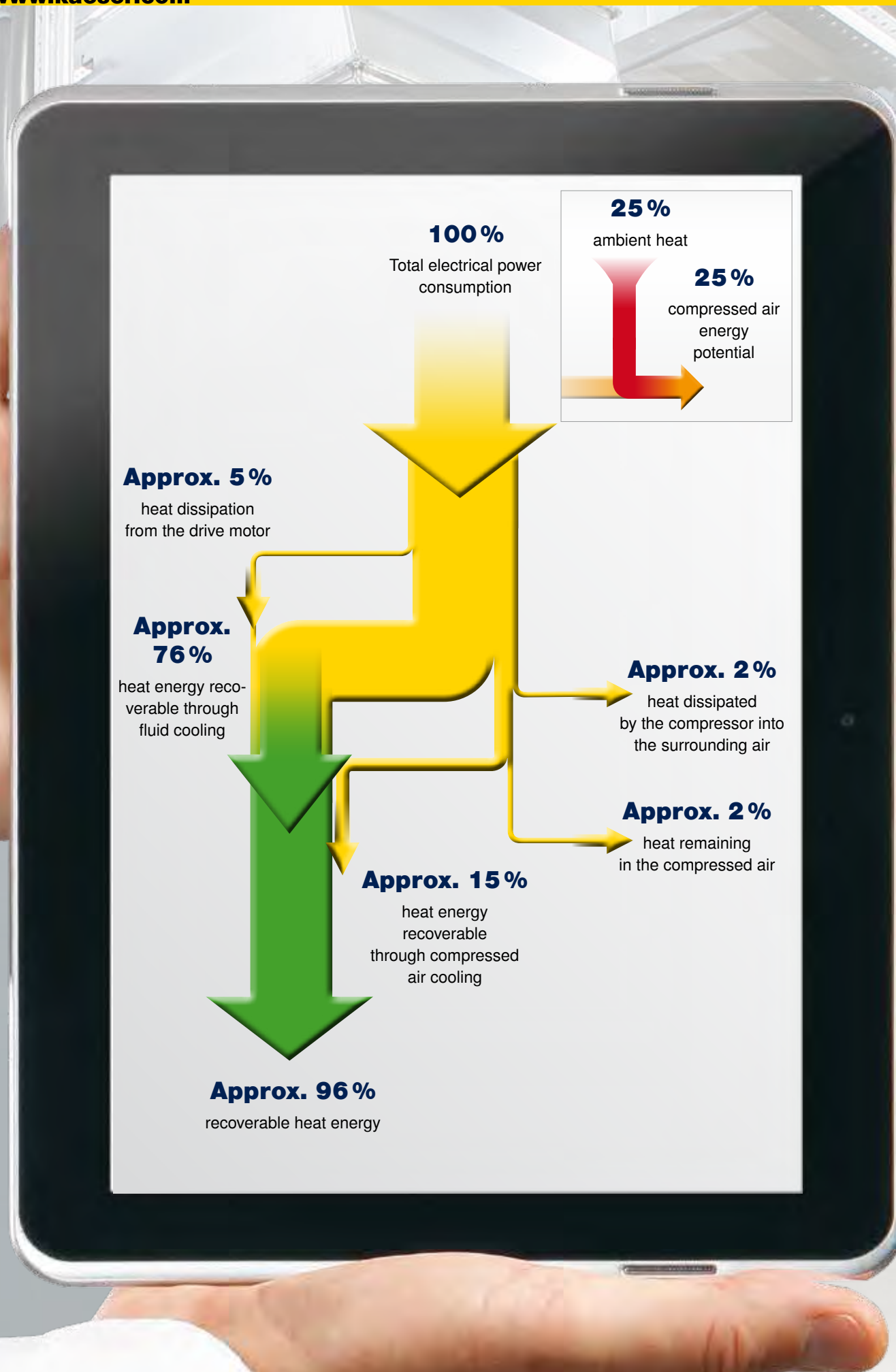

FSD series

Heat recovery



Systems for hot water usage

Systems comprising a plate heat exchanger, thermostatic valve and complete pipework require no additional space in the compressor and can recover 76% of the overall power consumption of FSD compressors by utilising the heat in the water.



Space heating with warm exhaust air

Heating made easy: Thanks to the high residual thrust radial fan, the reusable (warm) air can be easily ducted away to spaces that require heating.

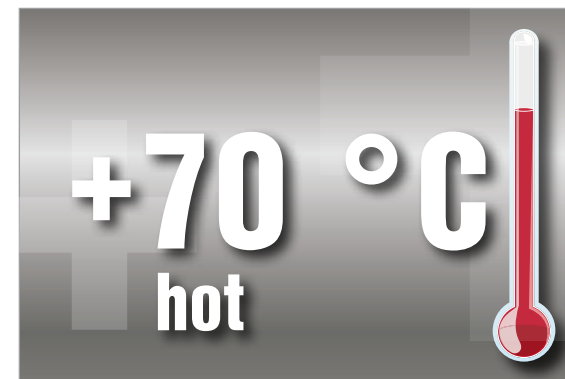

Process, heating and service water

Tap or process water, up to 70 °C, can be produced from reusable compressor heat via PWT and SWT heat exchanger systems. Please contact KAESER regarding higher temperature requirements.



Heat recovery a win

Amazingly, 100 percent of the electrical energy input to a compressor is converted into heat. From that, up to 96 percent is available for heat recovery purposes. Use this potential to your advantage!



Equipment

Complete unit

Ready-to-run, fully automatic, super-silenced, vibration damped, all panels powder coated. Suitable for use in ambient temperatures up to 45 °C.

Sound insulation

Panels lined with laminated mineral wool.

Vibration damping

Double insulated anti-vibration mountings using rubber bonded metal elements.

Airend

Genuine KAESER rotary screw, single stage SIGMA PROFILE airend with cooling fluid injection for optimised rotor cooling.

Drive

Direct, high-flex coupling, without gearing.

Electric motor

Super-Premium-Efficiency IE3 motor, quality German manufacture, IP 55, ISO F for additional reserve; PT 100 winding temperature sensor for motor monitoring; externally lubricated bearings.

Connection between electric motor and airend

Cast coupling flange.



Rotary screw airend with energy-saving SIGMA PROFILE rotors

Electrical components

Control cabinet to IP 54, containing automatic star-delta starter, motor overload protection, control transformer and floating contacts for ventilation control.

Fluid and air flow

Dry air intake filter, pneumatic inlet and venting valves, fluid reservoir with three-stage separator system, pressure relief valve, minimum pressure check valve, thermostatic valve and microfilter in coolant circuit, all fully piped using flexible couplings.

Cooling

Air-cooled; separate aluminium cooler for compressed air and cooling fluid; radial fan with separate electric motor, externally lubricated bearings. Water-cooled option with plate or shell and tube heat exchanger.

Heat recovery (Option)

PTG plate heat exchanger system or SWT fail-safe heat exchanger optionally available, installed externally.



SIGMA CONTROL 2

“Traffic light” LED indicators show operational status at a glance, plain text display, 30 selectable languages, soft-touch keys with icons, fully automated monitoring and control. Selection of Dual, Quadro, Vario, Dynamic and continuous control as standard. Interfaces: Ethernet; additional optional communication modules for: Profibus DP, Modbus, Profinet and Devicenet. SD-card slot for data-logging and updates; RFID reader, web server.

Technical specifications

Standard version

Model	Operating pressure bar	FAD*) Complete unit at operating pressure m ³ /min	Max. working pressure bar	Rated power drive motor kW	Dimensions W x D x H mm	Compressed air connection	Sound pressure level **) dB(A)	Weight kg
FSD 471	7.5	47.10	8	250	3000 x 2143 x 2360	DN 125 PN 16 DIN	79	6625
	10	40.50	10					
	12	35.50	12					
FSD 571	7.5	57.20	8	315	3000 x 2143 x 2360	DN 125 PN 16 DIN	79	6900
	10	46.40	12					
	13	39.45	13.5					
	15	34.40	15					

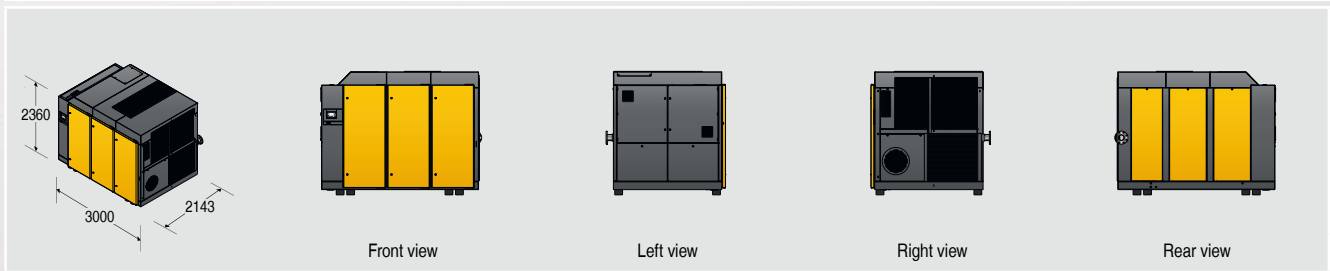

SFC - Version with variable speed drive

Model	Operating pressure bar	FAD*) Complete unit at operating pressure m ³ /min	Max. working pressure bar	Rated power drive motor kW	Dimensions W x D x H mm	Compressed air connection	Sound pressure level **) dB(A)	Weight kg
FSD 571 SFC	7.5	13.3 - 52.13	8.5	315	3610 x 2143 x 2360	DN 125 PN16 DIN	80 (Air-cooled)	7610
	10	9.80 - 45.10	15				77 (Water-cooled)	
	13	9.40 - 39.70	15					

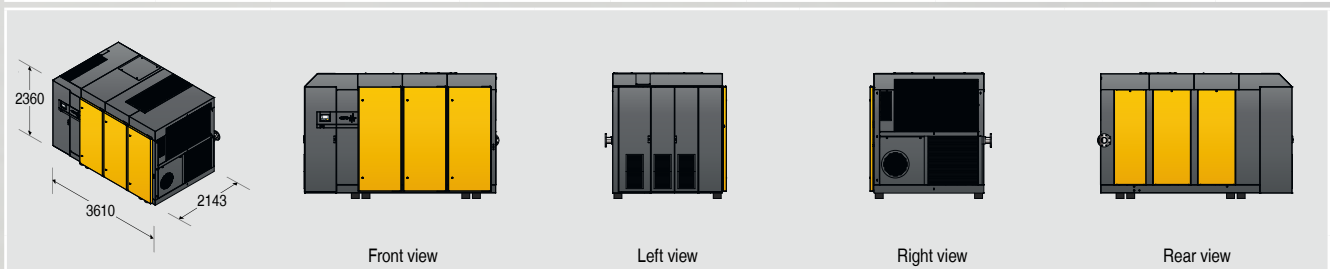

*) FAD complete system as per ISO 1217 : 2009, Annex C: Absolute intake pressure 1 bar (a), cooling and air intake temperature 20 °C

**) Sound pressure level as per ISO 2151 and the basic standard ISO 9614-2, tolerance: ± 3 dB (A)

General design

(Air-cooled)

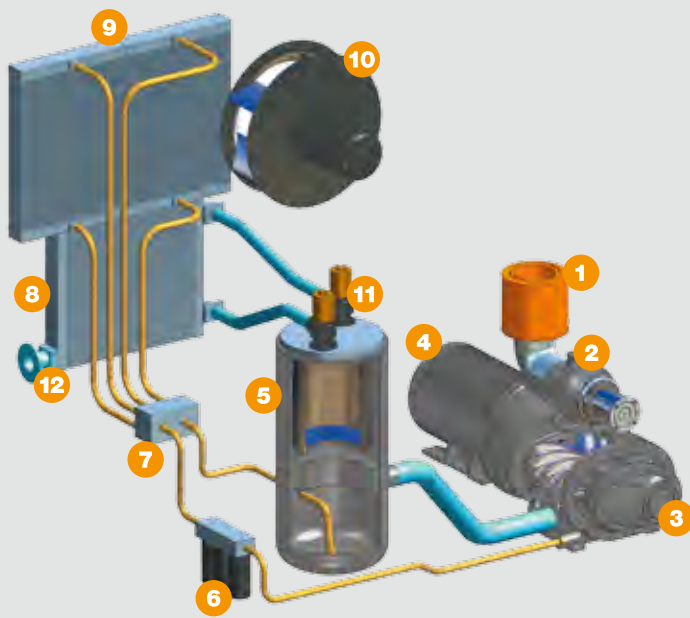

- 1 Inlet filter
- 2 Inlet valve
- 3 Airend
- 4 Premium efficiency drive motor
- 5 Oil separator tank
- 6 Oil filter
- 7 Thermostatic valve
- 8 Aftercooler
- 9 Oil cooler
- 10 Radial fan
- 11 Minimum pressure/check valve
- 12 Air outlet

(Water-cooled)

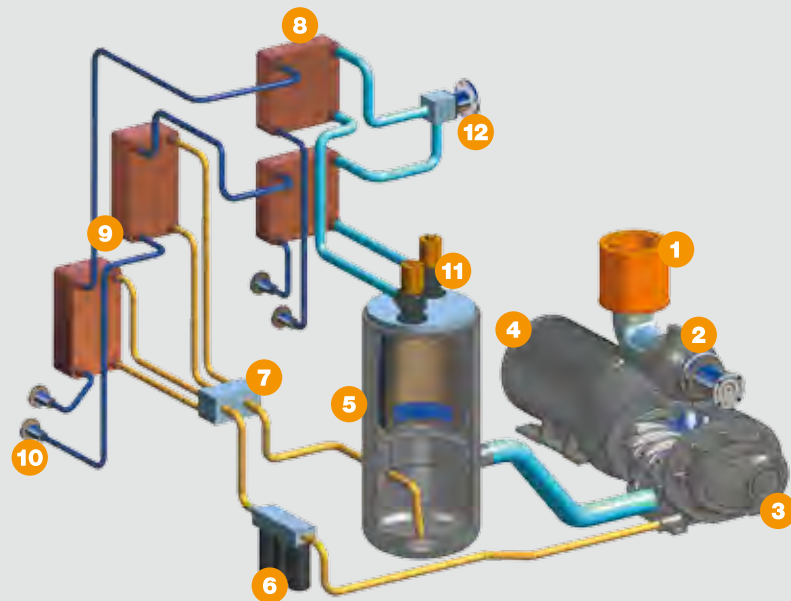

- 1 Inlet filter
- 2 Inlet valve
- 3 Airend
- 4 Premium efficiency drive motor
- 5 Oil separator tank
- 6 Oil filter
- 7 Thermostatic valve
- 8 Compressed air cooler
- 9 Oil cooler
- 10 Cooling water connections
- 11 Minimum pressure/check valve
- 12 Air outlet

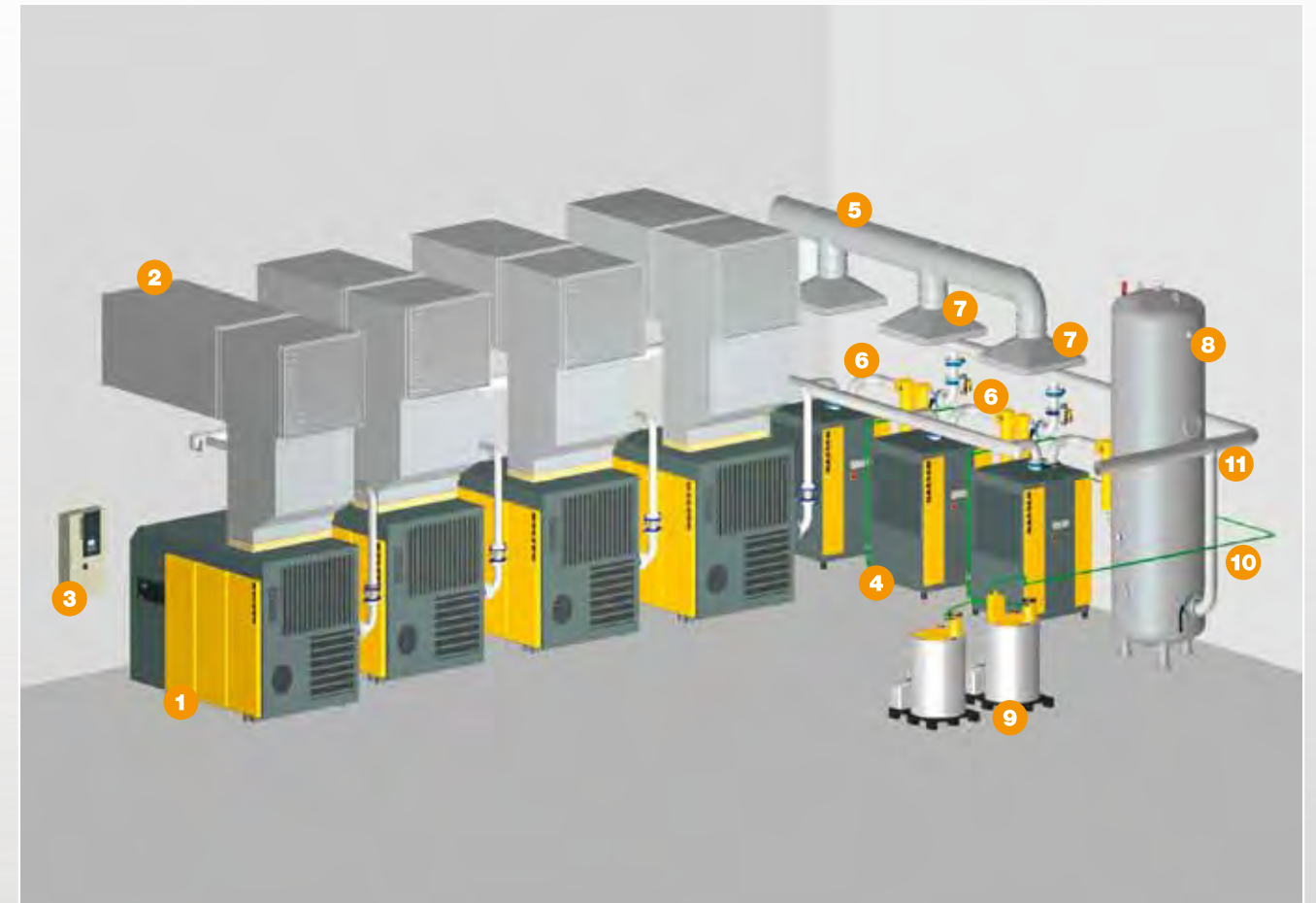

- 1 Rotary screw compressor
- 2 Exhaust air ducting for rotary screw compressor
- 3 SIGMA AIR MANGER master controller
- 4 Refrigeration dryer (redundant)
- 5 Refrigeration dryer exhaust air duct
- 6 Filtration (redundant)
- 7 Electronic air-main charging system (redundant)
- 8 Air receiver
- 9 AQUAMAT condensate treatment system
- 10 Condensate pipework
- 11 Compressed air pipework

A layout example for a compressed air station with FSD rotary screw compressors and compressed air treatment with energy-saving refrigeration dryers.

We provide specially tailored compressed air systems suited to specific spatial requirements; this includes compressed air treatment, exhaust ducting, compressed air pipework and condensate lines.

Choose the required grade of treatment according to your field of application:

Air treatment using a refrigeration dryer (pressure dew point +3°C)

Application examples: Selection of treatment classes to ISO 8573-1 (2010)

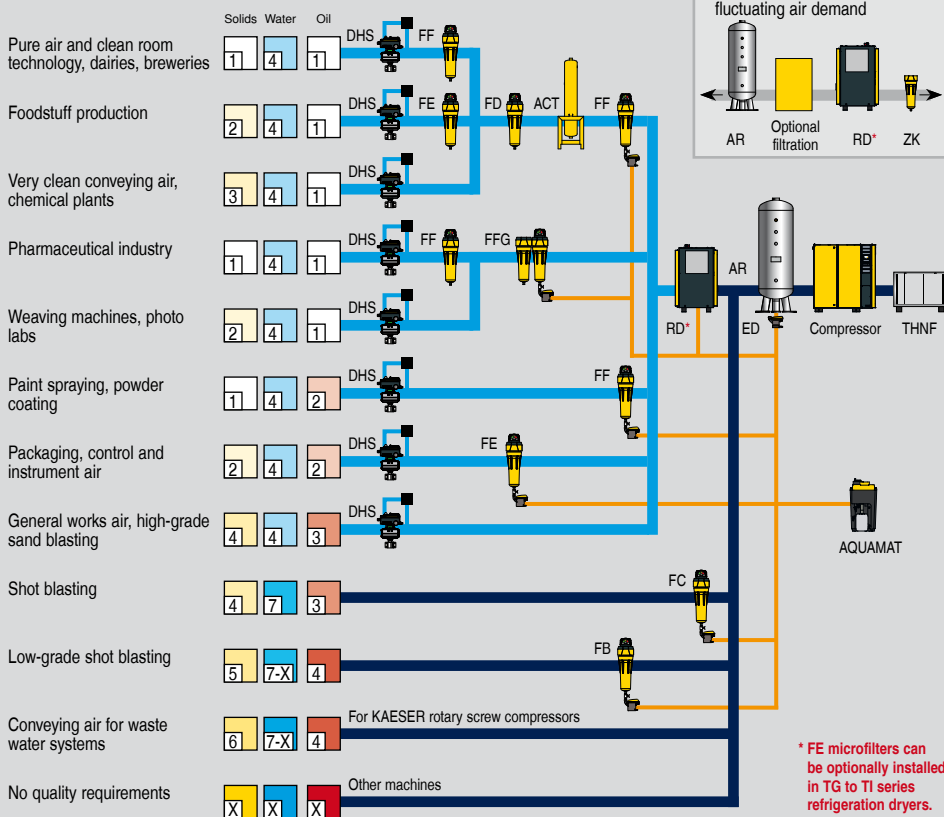

For non frost protected air systems: Compressed air treatment with a desiccant dryer (down to -70 °C pressure dew point)

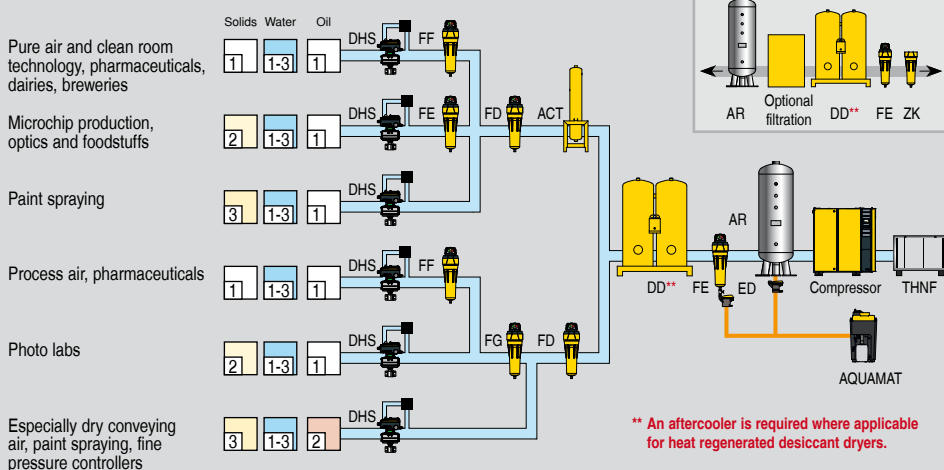

Explanation	
ACT	Activated carbon adsorber
AQUAMAT	AQUAMAT
DD	Desiccant dryer
DHS	Air-main charging system
AR	Air receiver
ED	ECO DRAIN
FB / FC	Pre-filter
FD	Particulate filter
FE / FF	Microfilter
FFG	Activated carbon and microfilter combination
FG	Activated carbon filter
RD	Refrigeration dryer
THNF	Bag filter
ZK	Centrifugal separator

Compressed air quality classes to ISO 8573-1(2010):

Solid particles / dust			
Class	max. particle count per m ³ of a particle size with d [µm]*		
	0.1 ≤ d ≤ 0.5	0.5 ≤ d ≤ 1.0	1.0 ≤ d ≤ 5.0
0	e.g. Consult KAESER regarding pure air and cleanroom technology		
1	≤ 20,000	≤ 400	≤ 10
2	≤ 400,000	≤ 6,000	≤ 100
3	Not defined	≤ 90,000	≤ 1,000
4	Not defined	Not defined	≤ 10,000
5	Not defined	Not defined	≤ 100,000
Class	Particle concentration C _p in mg/m ³ *		
6	0 < C _p ≤ 5		
7	5 < C _p ≤ 10		
X	C _p > 10		

Water	
Class	Pressure dew point, in °C
0	e.g. Consult KAESER regarding pure air and cleanroom technology
1	≤ -70 °C
2	≤ -40 °C
3	≤ -20 °C
4	≤ +3 °C
5	≤ +7 °C
6	≤ +10 °C
Class	Concentration of liquid water C _w in g/m ³ *
7	C _w ≤ 0.5
8	0.5 < C _w ≤ 5
9	5 < C _w ≤ 10
X	C _w > 10

Oil	
Class	Total oil concentration (fluid, aerosol + gaseous) [mg/m ³]*
0	e.g. Consult KAESER regarding pure air and cleanroom technology
1	≤ 0.01
2	≤ 0.1
3	≤ 1.0
4	≤ 5.0
X	> 5.0

*) At reference conditions 20°C, 1 bar(a), 0% humidity



KAESER KOMPRESSOREN AG

P.O. Box 2143 – 96410 Coburg – GERMANY – Tel +49 9561 640-0 – Fax +49 9561 640130
e-mail: productinfo@kaeser.com – www.kaeser.com