

## Marine Compressed Air Systems

More air, more savings ...  
SIGMA PROFILE 



# Marine air systems

## Full compressed air power ahead

KAESER KOMPRESSOREN offers a complete range of rotary screw compressors, blowers and air treatment components specifically designed for marine compressed air use, including application-specific service air, compressed air for nitrogen generation and blower air for wastewater treatment systems on large cruise ships. KAESER marine products are certified by all of the marine classification societies and are valued as much for their reliability as they are for their energy efficiency and long service life.

### Dependable and durable

Compressed air production is a matter of trust. Above all, this key energy source has to be there when you need it. The outstanding quality of KAESER compressors and rotary blowers provides you with that peace of mind. Strong vertical integration combined with an optimised mix of seasoned experience and creative technical innovation strength stand behind these quality aspirations.

### Energy efficient

In view of continuously soaring energy prices, it's no surprise that efficient energy usage is becoming an evermore important consideration in today's business environment. KAESER KOMPRESSOREN recognised this very early on, and the name is now synonymous with energy-efficient systems and compressed air solutions. At the heart of every rotary screw compressor lies a premium quality airend equipped with KAESER's renowned SIGMA PROFILE rotors which deliver more air with less energy consumption.

### Tailored solutions

Our extensive range of proven, dependable products comprising compressors, air treatment components and rotary blowers is available for every conceivable application, enabling our trained experts to provide a specially tailored compressed air system solution for any requirement and any operating environment.

### Made in Germany

The reliability, durability and energy efficiency of KAESER products have not come about by chance, but are the result of rigorous development and precision manufacturing. Every airend and blower block is meticulously built in accordance with KAESER's renowned quality standards by highly skilled workers at the company's factories in Coburg and Gera, located in central Germany.

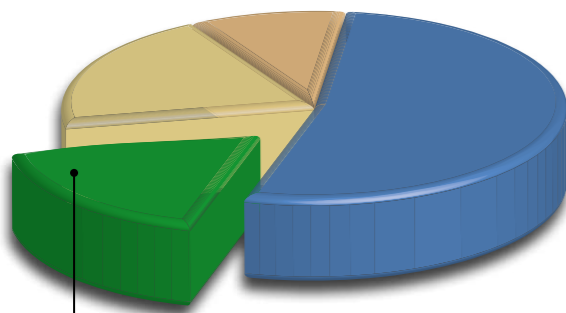

Energy cost savings through system optimisation



- Compressed air system investment
- Maintenance costs
- Energy costs
- Potential energy cost savings



# Nitrogen when you need it

## Dependable nitrogen generation



Image: HSD 711  
Series: HSD  
Motor power: 360 to 630 kW  
FAD: 64.30 to 85.20 m³/min  
Standard pressure: 8 to 14 bar (g)



Approved amongst others by:



### Redundancy and energy savings

The efficient SIGMA PROFILE rotors used in HSD series systems double your savings: Two identical, independently controllable rotary screw compressor packages maximise uptime and generate a dependable supply of compressed air and, in turn, nitrogen.



### Compact and ready-to-run

KAESER rotary screw compressors are compact, ready-to-run powerhouses. An optional variable speed drive with infinitely variable speed control provides additional flexibility and maintains consistent pressure. A quality refrigeration dryer delivers the dried compressed air necessary for nitrogen generation.

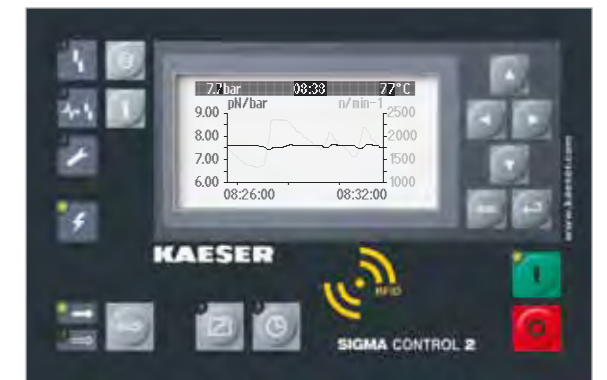

### Certified compressor control

The innovative SIGMA CONTROL 2 compressor controller ensures energy-efficient operation and optimised communication capability – in a choice of over 30 languages. With its integrated Web server, users can access compressor data via intranet / Internet.

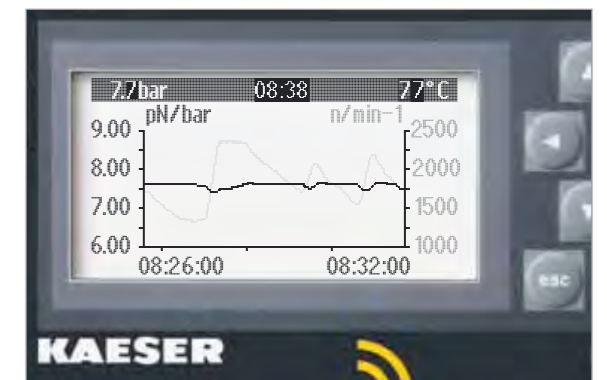

### Consistent pressure...

...for consistent nitrogen delivery. Operating pressure is reliably maintained within  $\pm 0.1$  bar. In turn, the consequent ability to reduce maximum system pressure also reduces energy costs. The relationship between pressure consistency and speed can be viewed directly on the SIGMA CONTROL 2 display.

# Efficient generation

## More nitrogen, more savings...



Image: ESD 442  
Series: ESD  
Motor power: 200 to 315 kW  
FAD: 23.33 to 49.40 m<sup>3</sup>/min  
Standard pressure: 8 to 14 bar(g)

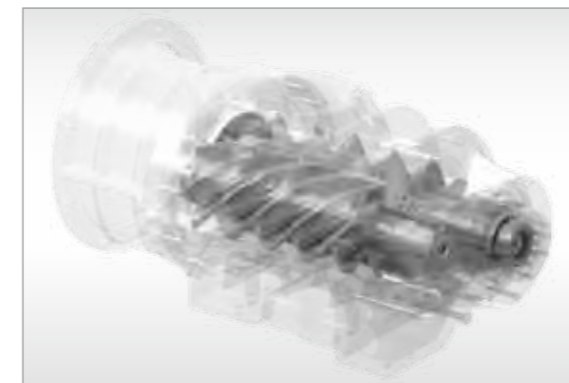

### Energy saving SIGMA PROFILE

At the heart of every KAESER rotary screw compressor system lies a premium quality airend featuring energy saving SIGMA PROFILE rotors. Operating at low speed, KAESER's airends are equipped with flow-optimised rotors for superior efficiency.



### Premium efficiency IE3 motors

The use of premium efficiency IE3 electric drive motors plays a key role in ensuring maximum efficiency of the on-board compressed air production process at all times.

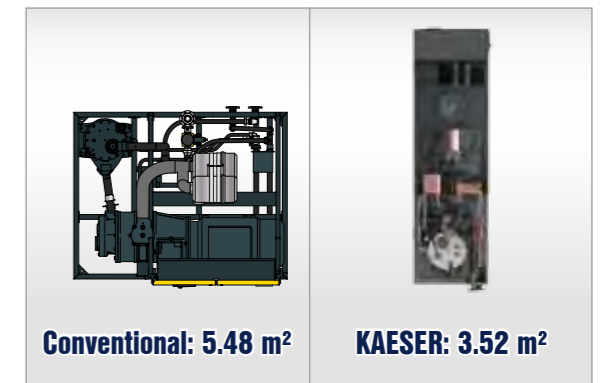

### Compact design

Space on ships is at a premium, which is why KAESER developed these compact powerhouses. They may look small in the machine room, but make no mistake, their performance is second to none.



### Integrated centrifugal separator

The newly developed KAESER stainless steel centrifugal separator included in the package removes condensate, thereby reducing the workload of downstream dryers and securing their efficiency.



Images: AIRCENTER 22, CSD 125 T  
Series: AIRCENTER, SM T to DSD T  
Motor power: 5.5 to 132 kW  
FAD: 0.90 to 23.70 m<sup>3</sup>/min  
Standard pressures: 8 to 14 bar(g)

# Working air

## Dependable assistant for every voyage



### 30 languages: SIGMA CONTROL 2

The SIGMA CONTROL 2 ensures efficient compressor control. The large display, RFID reader and 30 selectable languages ensure simple communication and maximum security. Multiple interfaces for exceptional flexibility. The SD card slot makes updates quick and easy.



### Compact and powerful

AIRCENTER systems are compact, all-in-one compressed air packages comprising a KAESER rotary screw compressor, an energy-saving refrigeration dryer and an integrated air receiver. The AIRCENTER SK 22 shown above has a footprint of only approximately one square metre.



### Excellent maintenance access

Excellent accessibility to all maintenance and service-relevant components minimises service effort and therefore costs. KAESER KOMPRESSOREN's newly developed centrifugal separator with electronic condensate drain is fitted as standard on CSD series compressors.



### Reliability you can count on

KAESER rotary screw compressors are highly resilient when it comes to extreme operating environments. Even in hot machine room conditions they continue to operate efficiently and dependably. Models suited to ambient temperatures up to 50 and 55 °C (standard: +45 °C) are available.



Image source: shutterstock.de

# Low pressure air

## Rotary blowers with OMEGA PROFILE rotors for marine applications

### Clarify, trim, convey

Supply and disposal facilities are required wherever there are people – even if temporarily. That is why appropriately dimensioned wastewater treatment systems are essential on cruise ships where crew and passengers total into the thousands. KAESER KOMPRESSOREN offers durable, energy-efficient, compact rotary blowers in various sizes and ratings to deliver a dependable supply of oxygen to the bacteria cultures in on-board clarifiers.

Rotary blowers are also used in anti-heeling systems which maintain a ship's trim during loading and unloading.

KAESER blower blocks feature high precision 5f 21 spur-ground timing gears with minimal backlash. They play a major role in contributing to the block's outstanding volumetric efficiency. Because spur-ground gears do not generate axial forces, cylinder roller bearings can be used, a feature unique to KAESER blower blocks. Because cylinder roller bearings have ten times the dynamic loading capacity of self-aligning bearings, their service life is significantly longer (100,000 hours). The result: Maximum system availability and minimal maintenance costs. Moreover, Q 2.5 rotor balancing, as with turbine rotors, results in quieter operation, extended service life and reduced maintenance.



### Dependable packages

Performing in all climatic conditions and with years of proven dependability, KAESER rotary blowers provide quality water treatment wherever you are.

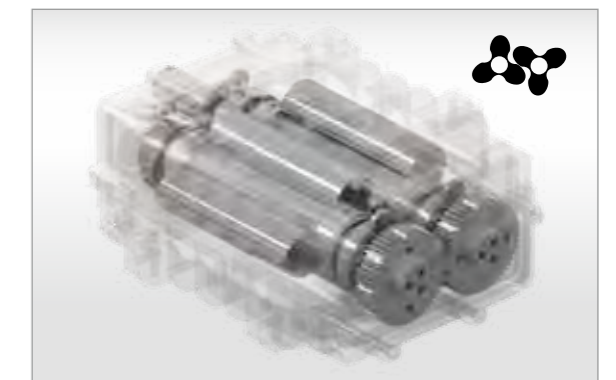

### Robust, durable blower blocks

Precision manufacture, three-lobe rotors, spur-ground gears and cylinder roller bearings: These are just some of the key factors that ensure the efficiency and durability of KAESER rotary blower blocks.



# Fish farming air

## Efficient feeding systems

Operators of fish farms, whether on-shore or off-shore, rely on a reliable supply of blower and / or compressed air in order to ensure continuous, correctly dosed food distribution.

This is another area where the many advantages of KAESER products score points.

KAESER's comprehensive range of rotary screw compressors and blowers means that the perfect system, or combination of systems, can be precisely tailored to suit any need.

All KAESER blowers and compressors are designed and built to provide maximum durability and reliability. Moreover, impressive energy efficiency helps keep the largest part of total system costs to a minimum, whilst low maintenance requirement reduces costs even further.



### Ready-to-run

Ready-to-run COMPACT blowers with OMEGA PROFILE rotors include all necessary sensors, a star-delta starter (or OFC frequency converter) and are CE and EMC certified. These systems minimise work and costs required for design, installation, certification, documentation and commissioning.



### Versatile rotary blowers

A suitable KAESER rotary blower is available for every conceivable requirement, whether it be a stand-alone unit or blower station, ready-to-connect package or a unit to be incorporated into a system with a master controller.



### Efficient rotary screw compressors

KAESER rotary screw compressors and treatment components deliver the right amount of compressed air at the required quality to suit any need. This is also achieved economically thanks to impressive energy efficiency.

Image courtesy of AKVA group

Courtesy of AKVA group

Courtesy of AKVA group



# Sea-land interface

## A smooth transition

### Compressed air keeps it moving

Compressed air is the first choice when it comes to moving bulk goods. Whether loading or purging, rotary blowers from KAESER KOMPRESSOREN are reliable, long-term partners for energy efficient air supply.

"Built for a lifetime" also applies to all land-based KAESER rotary screw compressors no matter what the application.

Specialised marine use includes keeping port and fjord entrances free from ice during the winter months for example.



### Moving bulk goods

KAESER KOMPRESSOREN offers a wide range of rotary blower systems and packages of various capacities for conveying bulk goods. According to requirement, the blower packages include completely integrated power electronics and are delivered ready for connection.



### Sound protection for Dolphin & Co.

KAESER portable compressors to provide air bubble curtains installed on wind turbine platform construction vessels to protect whales and dolphins from noise caused by the sound of the battering rams.



### For ice-free ports

Depending on the specific situation, rotary screw compressors or blowers are used to keep port entrances or navigation channels ice-free. If they are made by KAESER KOMPRESSOREN, the same thing applies in both cases: more air, more savings...



# Service everywhere

## From the high seas to the highest peaks

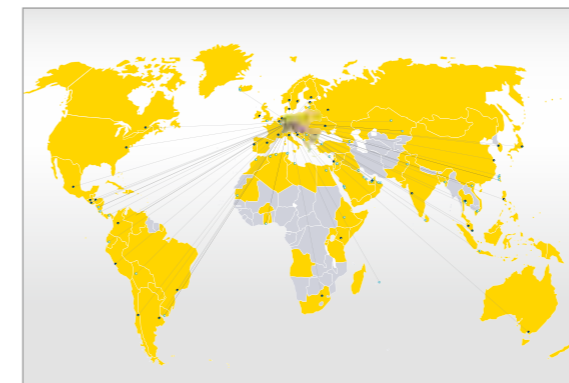

### Global service network

KAESER Service is just a moment away – no matter where you are. Globally networked and coordinated centrally from Coburg, qualified KAESER service specialists are available if needed at the next port of call as soon as the ship has docked.



### Computerised parts logistics

The automated parts warehouse in the KAESER Distribution Centre is the lynchpin for rapid despatch of required maintenance and spare parts to all corners of the planet. Fully automated parts identification ensures seamless processing.



### Integrated process control

Global networking and data communications mean that diagnostics can be carried out remotely and therefore enable on-demand maintenance of KAESER products. This leads to increased availability and maximises the overall cost-effectiveness of your compressed air supply.



### Risk-free genuine KAESER spares

KAESER's service personnel use only genuine maintenance and spare parts with proven long-term quality to ensure functional reliability and long life. Only KAESER original parts guarantee tested quality and optimum air supply performance.

# Rotary screw compressors

## Design and features

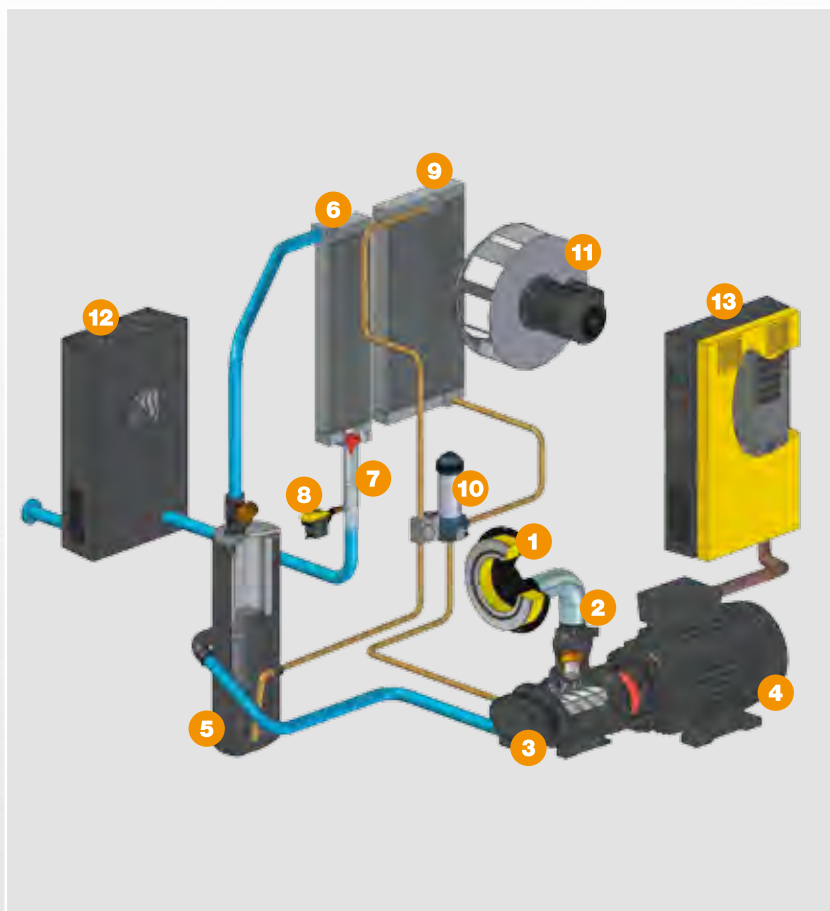

### T SFC version

- 1 Intake filter
- 2 Inlet valve
- 3 Airend
- 4 Drive motor
- 5 Fluid separator tank
- 6 Compressed air aftercooler
- 7 Centrifugal separator
- 8 Condensate drain (ECO DRAIN)
- 9 Fluid cooler
- 10 Fluid filter
- 11 Radial fan
- 12 Integrated refrigeration dryer
- 13 Switching cabinet with integrated SFC frequency converter

### Complete unit

Ready-to-run, fully automatic, vibration-isolated, suitable for ambient temperatures up to +55 °C. Service-friendly, compact design. Optionally available with integrated refrigeration dryer and / or integrated frequency converter. Integrated centrifugal separator with condensate drain for pre-separation of air moisture (from ASD).

### Airend

Genuine KAESER single-stage rotary screw airend with SIGMA PROFILE rotors and cooling-fluid injection for optimised rotor cooling.

### Fluid and air flow

Dry-air filter with pre-separation, inlet silencer, pneumatic inlet and vent valves, cooling-fluid separator reservoir with three-stage separator system, pressure release valve, minimum pressure check valve, thermostatic valve

and fluid filter in cooling fluid system, plate-type or shell and tube heat exchanger for fluid and compressed air



cooling, air-cooled to ASD series / air-, water- and seawater-cooling available from BSD (44kW) series.

### Electrical components

Premium efficiency IE3 drive motor, special marine version. Control cabinet IP 54 enclosed, control cabinet ventilation, automatic star-delta contactor configuration, overload relay, control

transformer. SFC version also equipped with frequency converter.

### SIGMA CONTROL 2

Marine-certified compressor control system. "Traffic light" LED indicators show operational status at a glance, plain text display, 30 selectable languages, durable keys with icons, fully automated monitoring and control. Selection of multiple control modes as standard. Interfaces: Ethernet; additional optional communication modules for: Profibus DP, Modbus, Profinet and Devicenet. SD-card slot for data-logging and updates. RFID reader, web server.

# Technical Specifications

Standard version (440 V / 60 Hz - 3 Ph)

Model	Max. operating pressure bar	FAD *) Complete unit at max. working pressure		Rated motor power kW	Dimensions W x D x H mm		Air connection m³/min	Power supply		Cooling		Weight kg	
		m³/h	m³/min		440 V / 60 Hz / 3 Ph	380 V / 50 Hz / 3 Ph		Air	Water				
<b>SM 9</b>	8 14	54 33	0.90 0.55	5.5	630 x 762 x 1100		G 3/4	●	○	●	–	210	
<b>SM 12</b>	8 14	72 46	1.20 0.77	7.5	630 x 762 x 1100		G 3/4	●	○	●	–	220	
<b>SM 15</b>	8 14	90 59	1.50 0.98	9	630 x 762 x 1100		G 3/4	●	○	●	–	320	
<b>SK 22</b>	8 14	120 79	2.00 1.31	11	750 x 895 x 1260		G 1	●	○	●	–	312	
<b>SK 25</b>	8 14	150 107	2.50 1.78	15	750 x 895 x 1260		G 1	●	○	●	–	320	
<b>ASK 32</b>	8 14	189 122	3.15 2.03	18.5	1130 x 830 x 1255		G 1 1/4	●	○	●	–	420	
<b>ASK 35</b>	8 14	210 142	3.50 2.37	22	1130 x 860 x 1255		G 1 1/4	●	○	●	–	420	
<b>ASD 37</b>	8 14	225 150	3.75 2.50	22	1350 x 994 x 1505		G 1 1/4	●	○	●	–	655	
<b>ASD 47</b>	8 14	276 185	4.60 3.08	30	1350 x 994 x 1505		G 1 1/4	●	○	●	–	665	
<b>ASD 57</b>	8 14	325 210	5.42 3.50	30	1350 x 994 x 1505		G 1 1/4	●	○	●	–	720	
<b>BSD 75</b>	8 14	401 269	6.69 4.48	37	1590 x 1090 x 1750		G 1 1/2	●	○	○	●	940	
<b>BSD 83</b>	8 14	491 317	8.19 5.29	45	1590 x 1090 x 1700		G 1 1/2	●	○	○	●	970	
<b>CSD 105</b>	8 14	587 390	9.79 6.50	55	1760 x 1110 x 1935		G 2	●	○	○	●	1250	
<b>CSD 125</b>	8 14	709 470	11.82 7.84	75	1760 x 1110 x 1935		G 2	●	○	○	●	1280	
<b>CSDX 140</b>	8 14	843 570	14.04 9.50	75	2110 x 1290 x 1950		G 2	●	○	○	●	1740	
<b>CSDX 165</b>	8 14	963 684	16.05 11.40	90	2110 x 1290 x 1950		G 2	●	○	○	●	1835	
<b>DSD 202</b>	8 14	1143 900	19.05 15.00	110	2300 x 1495 x 1930 ** 2300 x 1495 x 1930 **		DN 65 / PN 16	●	○	○	●	3000	
<b>DSD 238</b>	8 14	1422 1050	23.70 17.50	132	2300 x 1495 x 1930 ** 2300 x 1495 x 1930 **		DN 65 / PN 16	●	○	○	●	3200 3300	
<b>DSD 302</b>	8	1650	27.50	160	2300 x 1495 x 1930 **		DN 65 / PN 16	●	○	○	●	3400	
<b>DSDX 302</b>	8	1710	28.50	160	2550 x 1705 x 1930 **		DN 80 / PN 16	●	○	○	●	3900	
<b>ESD 352</b>	8 14	2148 1400	35.80 23.33	200	3525 x 1100 x 2250 **		DN 80 / PN 16	●	○	–	●	4150	
<b>ESD 442</b>	8	2556	42.60	250	3525 x 1100 x 2250		DN 80 / PN 16	●	○	–	●	4250	
	8	2960	49.40	315	3650 x 1100 x 2250							4250	
	14	1640	27.33	250	3525 x 1100 x 2250							4250	
	14	2080	34.67	250	3525 x 1100 x 2250							4250	
	14	2485	41.42	315	3650 x 1100 x 2250							4400	
<b>FSD 571</b>	8	3388	56.47	315	3010 x 2177 x 2360		DN 125 / PN 16	●	○	–	●	6000	
<b>HSD 651</b>	8	3858	64.30	160	200	3510 x 2000 x 2250		DN 150 / PN 16	●	○	–	●	7900
<b>HSD 711</b>	8 14	4296 2800	71.60 46.67	200 200	200	3510 x 2000 x 2250		DN 150 / PN 16	●	○	–	●	8300
<b>HSD 761</b>	8 14	4704 3040	78.40 50.67	250 200	200	3510 x 2000 x 2250		DN 150 / PN 16	●	○	–	●	8400
<b>HSD 831</b>	8	5112	85.20	250	250	3510 x 2000 x 2250		DN 150 / PN 16	●	○	–	●	8500
	14	3280	54.67	200	200	3510 x 2000 x 2250							8500
	14	3715	61.92	250	200	3510 x 2000 x 2250							8700
	14	4155	69.25	250	250	3510 x 2000 x 2250							8700
	14	4560	76.00	315	250	3565 x 2000 x 2250							8800
	14	4970	82.83	315	315	3565 x 2000 x 2250						8900	

\*) FAD complete system as per ISO 1217 : 2009, Annex C: absolute inlet pressure 1 bar (a), cooling- and air inlet temperature 20 °C

\*\* Water-cooled version

● Standard ○ Option – Not available

## Technical Specifications

SFC – Version with variable speed drive (440 V / 60 Hz - 3 Ph)

Model	Max. operating pressure bar	FAD *) Complete unit at max. working pressure		Rated motor power kW	Dimensions W x D x H mm	Air connection m³/min	Power supply		Cooling		Weight kg
		m³/h	m³/min				440 V / 60 Hz / 3 Ph	380 V / 50 Hz / 3 Ph	Air	Water	
SK 22 SFC	8 14	37-119 33-82	0.6-2.0 0.6-1.4	11	750 x 895 x 1260	G 1	●	○	●	–	330
SK 25 SFC	8 14	48-157 49-115	0.8-2.6 0.8-1.9	15	750 x 895 x 1260	G 1	●	○	●	–	340
ASK 32 SFC	8 14	55-183 37-124	0.9-3.1 0.6-2.1	18.5	1130 x 850 x 1255	G 1 1/4	●	○	●	–	425
ASD 32 SFC	8	40-205	0.7-3.4	18.5	1850 x 921 x 1505	G 1 1/4	●	○	●	–	685
ASD 37 SFC	8 14	49-247 49-183	0.8-4.1 0.8-3.1	22	1850 x 921 x 1505	G 1 1/4	●	○	●	–	760
ASD 47 SFC	8 14	64-322 40-227	1.1-5.4 0.7-3.8	30	1850 x 921 x 1505	G 1 1/4	●	○	●	–	770
BSD 75 SFC	8 14	101-456 68-326	1.69-7.6 1.14-5.43	37	1665 x 1090 x 1700	G 1 1/2	●	○	○	●	1080
CSD 85 SFC	8 14	116-482 64-344	2.0-8.0 1.1-5.7	45	1760 x 1110 x 1935	G 2	●	○	○	●	1220
CSD 105 SFC	8 14	130-583 79-411	2.2-9.7 1.3-6.9	55	1760 x 1110 x 1935	G 2	●	○	○	●	1340
CSD 125 SFC	8 14	170-742 105-530	2.8-12.4 1.8-8.8	75	1760 x 1110 x 1935	G 2	●	○	○	●	1360
CSDX 140 SFC	8 14	202-807 111-585	3.4-13.5 1.9-9.8	75	2110 x 1290 x 1950	G 2	●	○	○	●	1758
CSDX 165 SFC	8 14	229-978 159-708	3.8-16.3 2.7-11.8	90	2110 x 1290 x 1950	G 2	●	○	○	●	1975
DSD 202 SFC	8 14	252-1212 234-872	4.2-20.2 3.9-14.5	110	2905 x 1495 x 1930 **	DN 65 / PN 16	●	○	○	●	3660
DSD 238 SFC	8 14	354-1368 234-939	5.9-22.8 3.9-15.7	132	2905 x 1495 x 1930 **	DN 65 / PN 16	●	○	○	●	3800
DSDX 302 SFC	8	388-1692	6.5-28.2	160	3155 x 1945 x 2040 **	DN 80 / PN 16	●	○	○	●	4530
ESD 352 SFC	8 14	512-2111 305-1470	8.5-35.2 5.1-24.5	200	3100 x 2000 x 2040**	DN 125 / PN 16	●	○	○	●	5705
ESD 442 SFC	8 14	607-2422 361-1680	10.1-40.4 6.0-28.0	250	3100 x 2000 x 2040	DN 125 / PN 16	●	○	○	●	5725
FSD 571 SFC	8	804	13.4	315	3610 x 2215 x 2260	DN 125 / PN 16	●	○	○	●	7510
HSD 761 SFC	8	699-4240	11.7-70.7	250 / 160	4370 x 2145 x 2250	DN 150 / PN 16	●	○	–	●	9450
HSD 831 SFC	8 14 14 14	699-4924 468-3498 468-3750 468-3912	11.7-82.0 7.8-58.3 7.8-62.5 7.8-65.2	315 / 200 250 / 200 250 / 200 315 / 250	4370 x 2145 x 2250	DN 150 / PN 16	●	○	–	●	9950 9950 9950 9950

\*) FAD complete system as per ISO 1217 : 2009, Annex C: absolute inlet pressure 1 bar (a), cooling- and air inlet temperature 20 °C

\*\*) Water-cooled version

● Standard ○ Option – Not available

## Technical Specifications

T – version with integrated refrigeration dryer (refrigerant R 134a) (440 V / 60 Hz - 3 Ph)

Model	Max. operating pressure bar	FAD *) Complete unit at max. working pressure		Rated motor power kW	Dryer power consumption kW	Pressure dew point °C	Dimensions W x D x H mm	Air connection m³/min	Power supply		Cooling		Weight kg
		m³/h	m³/min						440 V / 60 Hz / 3 Ph	380 V / 50 Hz / 3 Ph	Air	Water	
SM 9 T	8	54	0.90	5.5	0.54	3	630 x 1074 x 1100	G 3/4	●	○	●	–	275
SM 12 T	8	72	1.20	7.5	0.54	3	630 x 1074 x 1100	G 3/4	●	○	●	–	285
SM 15 T	8	90	1.50	9	0.54	3	630 x 1074 x 1100	G 3/4	●	○	●	–	295
SK 22 T	8	120	2.00	11	0.8	3	750 x 1240 x 1260	G 1	●	○	●	–	387
SK 25 T	8	150	2.50	15	0.8	3	750 x 1240 x 1260	G 1	●	○	●	–	395
ASK 32 T	8	189	3.15	18.5	1.1	3	1480 x 780 x 1255	G 1	●	○	●	–	480
ASK 35 T	8	210	3.50	22	1.1	3	1480 x 780 x 1255	G 1	●	○	●	–	495
ASD 37 T	8	225	3.75	22	1.64	3	1850 x 921 x 1505	G 1 1/4	●	○	●	–	800
ASD 47 T	8	276	4.60	30	1.64	3	1850 x 921 x 1505	G 1 1/4	●	○	●	–	810
ASD 57 T	8	325	5.42	30	1.64	3	1850 x 921 x 1505	G 1 1/4	●	○	●	–	870
BSD 75 T	8	401	6.69	37	2.1	3	1990 x 1090 x 1700	G 1 1/2	●	○	○	●	1065
BSD 83 T	8	491	8.19	45	2.1	3	1990 x 1090 x 1700	G 1 1/2	●	○	○	●	1085
CSD 105 T	8	587	9.79	55	2	3**	2160 x 1110 x 1935	G 2	●	○	○	●	1420
CSD 125 T	8	709	11.82	75	2.8	3**	2160 x 1110 x 1935	G 2	●	○	○	●	1480
CSDX 140 T	8	843	14.04	75	3.2	3**	2510 x 1290 x 1950	G 2	●	○	○	●	2005
CSDX 165 T	8	936	16.05	90	3.2	3**	2510 x 1290 x 1950	G 2	●	○	○	●	2100
DSD 202 T	8	1143	19.05	110	4.4	3**	3310 x 1495 x 2040	DN 65 / PN 16	●	○	○	●	3550
DSD 238 T	8	1422	23.70	132	4.4	3**	3310 x 1495 x 2040	DN 65 / PN 16	●	○	○	●	3770

\*) FAD complete system as per ISO 1217 : 2009, Annex C: absolute inlet pressure 1 bar (a), cooling- and air inlet temperature 20 °C

\*\*) Dryer water-cooled

\*\*) Air-cooled dryer pressure dew point with T<sub>a</sub>=20 °C and 30% relative humidity; water-cooled dryer pressure dew point with T<sub>a</sub>=45 °C; 55% relative humidity (cooling water inlet 30 °C)

● Standard ○ Option – Not available

# Refrigeration dryers

## Design and features

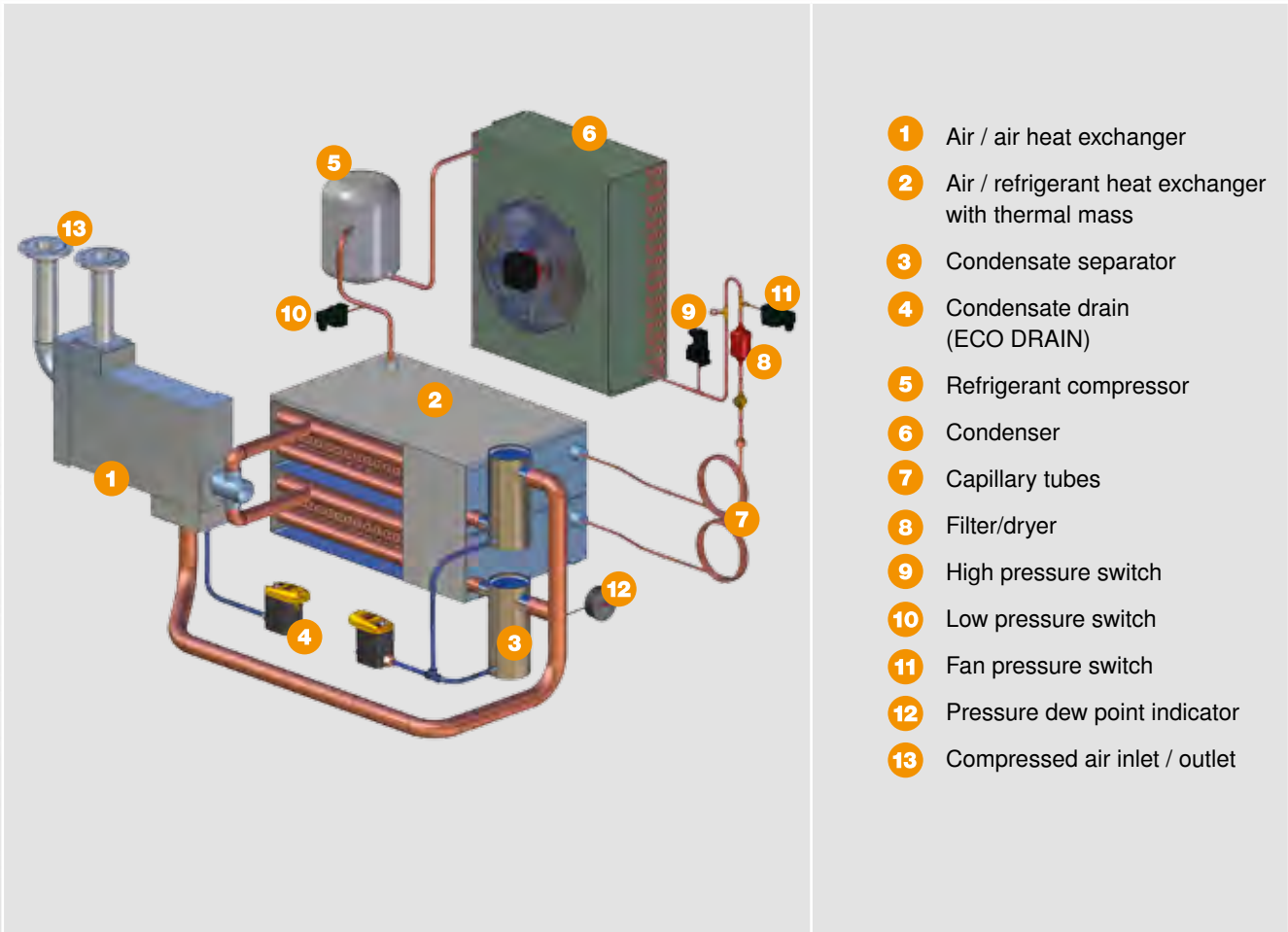

### General design

Compact tower construction with removable side panels, all materials used are CFC-free; all cold components are insulated; the built-in control cabinet is enclosure-protected to IP 54, air to air heat exchanger, condensate separation system, automatic condensate drain.

### Refrigerant circuit

Hermetically-sealed refrigerant circuit features large heat-exchanger surface area and service valves; energy saving control.



# Rotary Blowers

## Design and features

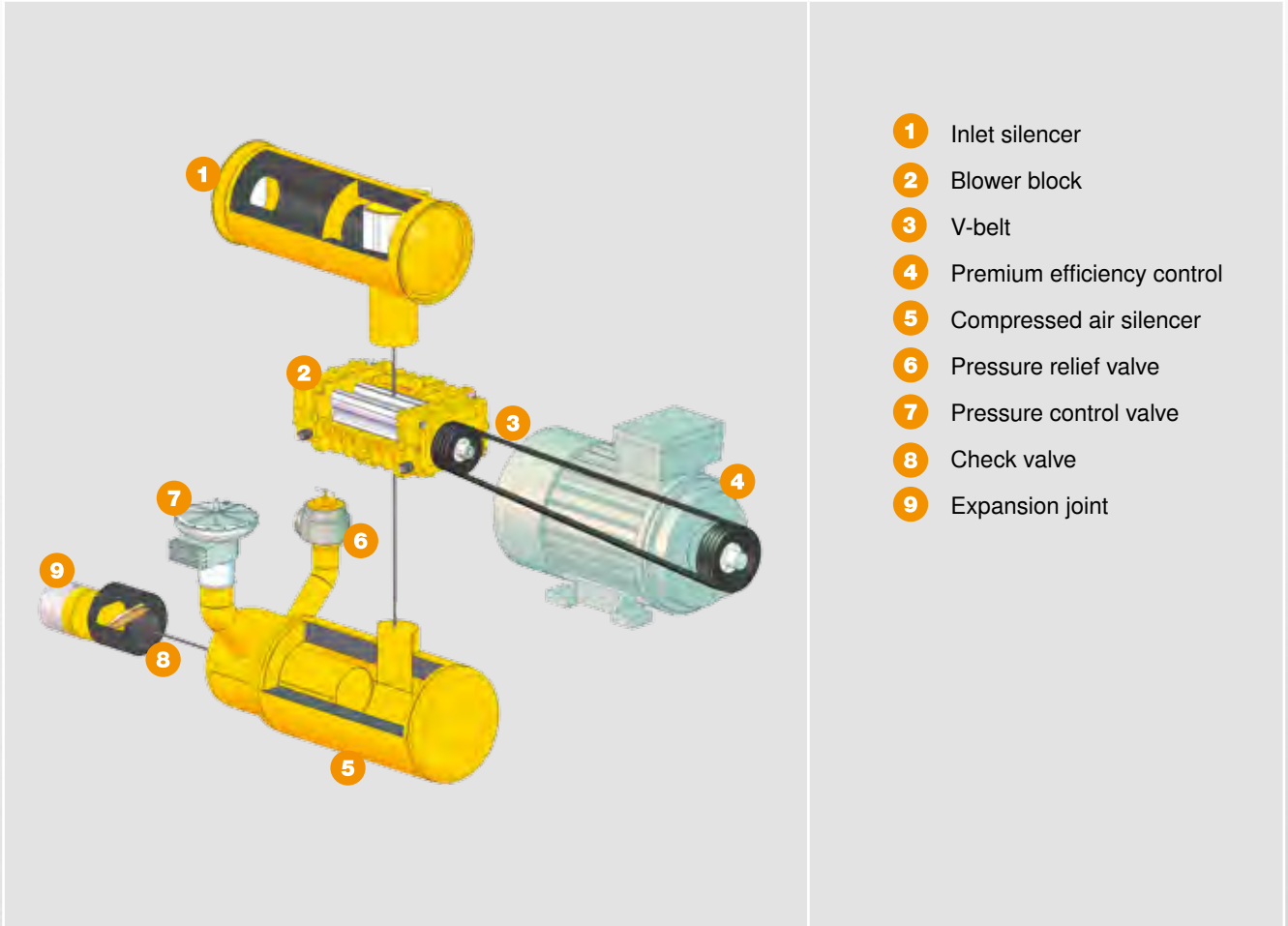

### Complete system

Ready for operation, fully automatic, vibration-isolated, optionally available with integrated control cabinet.

### Omega Control

The OMEGA CONTROL monitors all operational parameters, displays data in plain text and is able to communicate with master control systems and centralised control systems.

### Blower block

Single-stage rotary blower block, fine-balanced rotors, rotor tips with integrated sealing strips, spur-ground timing gears, gear chamber with oil charge, durable bearings, labyrinth seals. V-belt drive with automatic belt tensioning.

### Electrical components

Premium efficiency IE2 / IE3 drive motor, special marine version. Available with refrigeration dryer IP 54 enclosure protection, control cabinet ventilation. Automatic star-delta contactor configuration, overload relay, control transformer. SFC version also equipped with frequency converter. Optionally available with integrated Omega Control for monitoring of operating parameters.



# KAESER – The world is our home

As one of the world's largest manufacturers of rotary screw compressors, KAESER KOMPRESSOREN is represented throughout the world by a comprehensive network of branches, subsidiary companies and authorised partners in over 100 countries.

With innovative products and services, KAESER KOMPRESSOREN's experienced consultants and engineers help customers to enhance their competitive edge by working in close partnership to develop progressive system concepts that continuously push the boundaries of performance and compressed air efficiency. Moreover, the decades of knowledge and expertise from this industry-leading system provider are made available to each and every customer via the KAESER group's global computer network.

These advantages, coupled with KAESER's worldwide service organisation, ensure that all products operate at the peak of their performance at all times and provide maximum availability.



## KAESER KOMPRESSOREN AG

P.O. Box 2143 – 96410 Coburg – GERMANY – Tel +49 9561 640-0 – Fax +49 9561 640130  
[www.kaeser.com](http://www.kaeser.com) – e-mail: [productinfo@kaeser.com](mailto:productinfo@kaeser.com)